

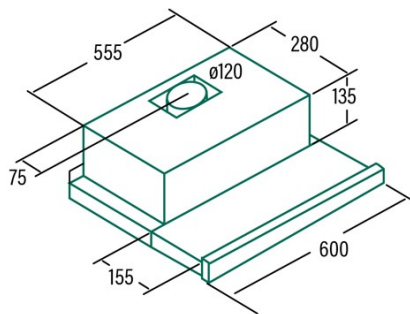

AIR 201 600 BLANCA

Cod. 02033077

EAN 8422248083195



GENERAL INFORMATION

EAN/UPC	8422248083195
Subfamily	Telescopic

Product sheet according to directives EU65/2014 - EN61591, EN60704-2-13, EN50564

AEC (Annual energy consumption) (kWh/year)	49,7
EEL class (energy efficiency class)	D
FDE (fluid dynamic efficiency)	5,2
FDE class (fluid dynamic efficiency class)	F
LE (light efficiency) (lux/W)	27,3
LE class (light efficiency class)	B
GFE (grease filtering efficiency)	58,6
GFE class (grease filtering efficiency class)	E
Airflow in normal mode MIN (m3/h)	130
Airflow in normal mode MAX (m3/h)	200
Acoustic power in normal mode MIN (dB)	51
Acoustic power in normal mode MAX (dB)	65
Po (energy consumption in off mode) (W)	0
Ps (energy consumption in standby mode) (W)	0

Integration directive EU 66/2014

f (time increase factor)	1,8
EEL (Energy Efficiency Index)	88,4
QBEP (maximum efficiency at air flow point) (m3/h)	92,9
PBEP (maximum efficiency at pressure point) (Pa)	137
WBEP (power consumption at maximum efficiency) (W)	69
WL (nominal power lighting system) (W)	5,5
EMIDDLE (Average illuminance on the cooking surface) (lux)	150

Characteristics

Motor quantity	1
Motor model	TF
Control technology	Electronic Touch Control
Booster	-
Power levels	3
Timer	-
Filter saturation indicator	-
Charcoal filter replacement indicator	-
Dimmer function	-
Connectivity	No
Remote control	-
Display	-

Lighting

Light model	LED E-14
Ray technology	LED

Electric connection

Nominal voltage (V)	220-240
Nominal frequency (Hz)	50
Electric shock protection	Class II